

Nov. 17, 1936.

E. S. KARSTENS

2,061,425

CONCRETE PUMPING MACHINE

Filed Aug. 21, 1934

6 Sheets-Sheet 1

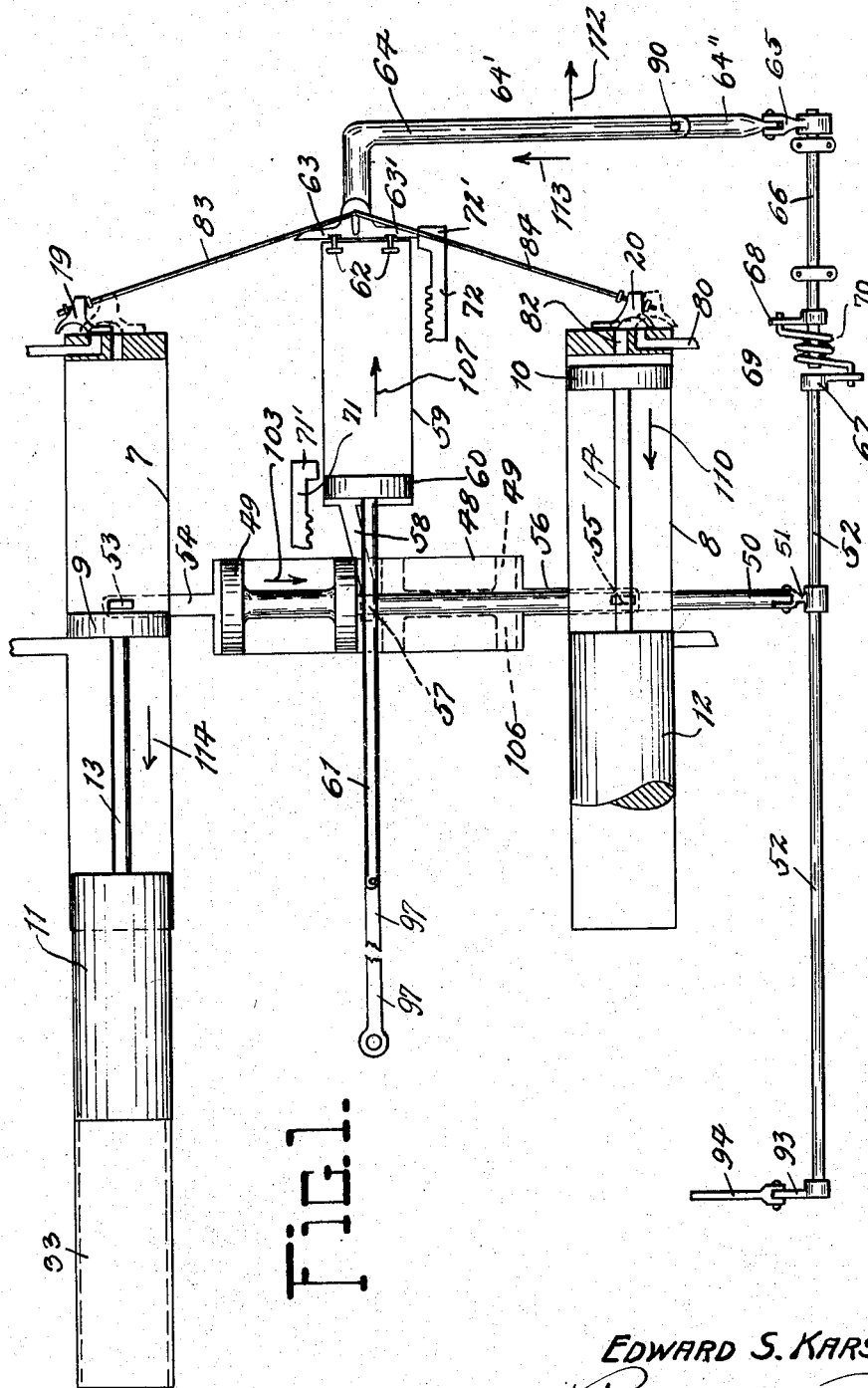

FIG. 1.

INVENTOR

EDWARD S. KARSTENS.

BY

Robert Robb

ATTORNEYS

Nov. 17, 1936.

E. S. KARSTENS

2,061,425

CONCRETE PUMPING MACHINE

Filed Aug. 21, 1934

6 Sheets-Sheet 2

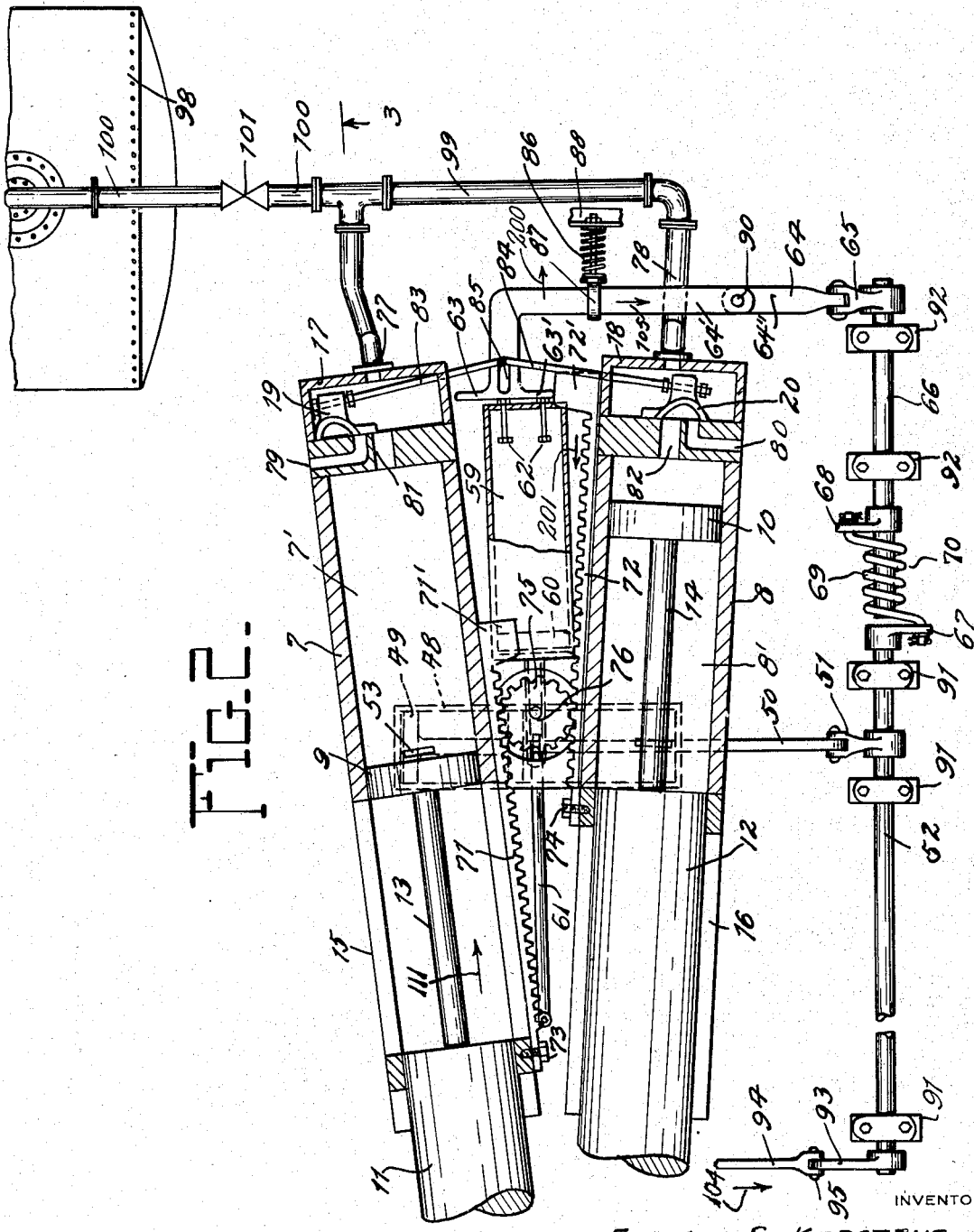

FIG. 2.

INVENTOR
EDWARD S. KARSTENS.
 BY *Robert Pobb*
 ATTORNEYS

Nov. 17, 1936.

E. S. KARSTENS

2,061,425

CONCRETE PUMPING MACHINE

Filed Aug. 21, 1934

6 Sheets-Sheet 3

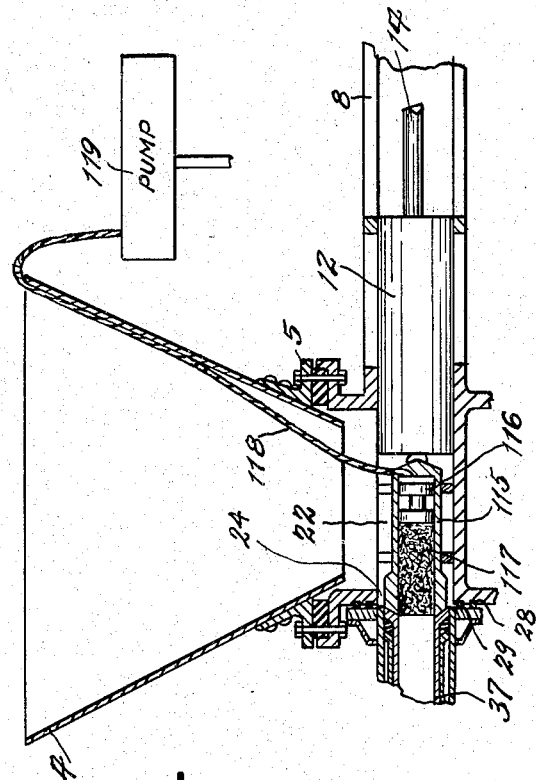
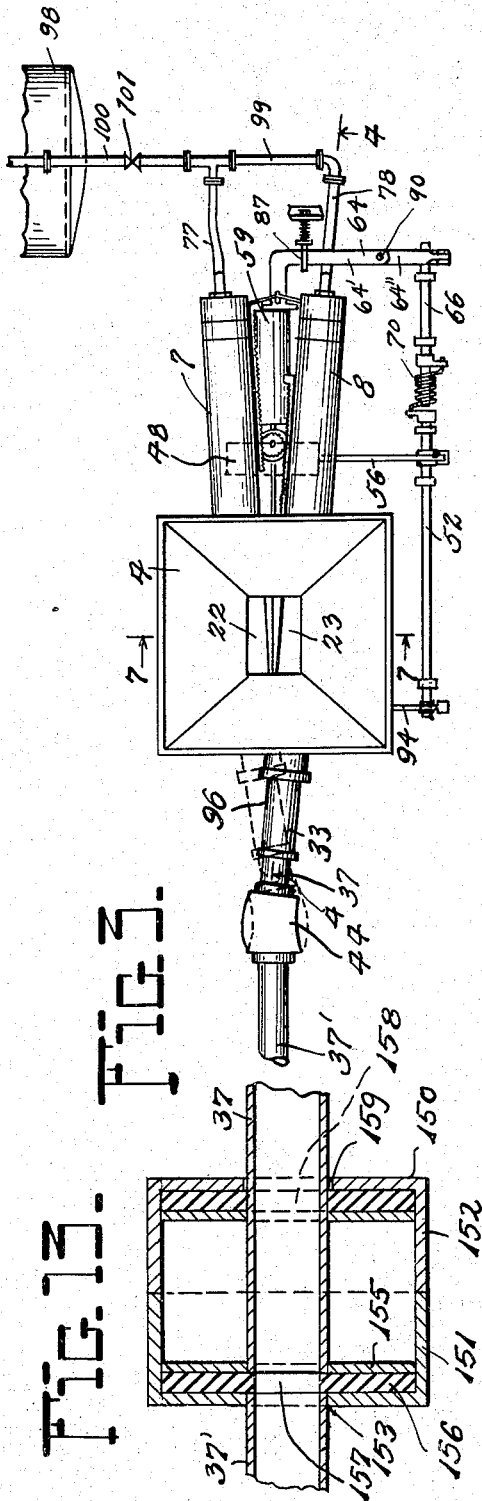

FIG. 9.

FIG. 10.

INVENTOR

EDWARD S. KARSTENS.

BY

Robert Robb

ATTORNEYS

Nov. 17, 1936.

E. S. KARSTENS

2,061,425

CONCRETE PUMPING MACHINE

Filed Aug. 21, 1934

6 Sheets-Sheet 3

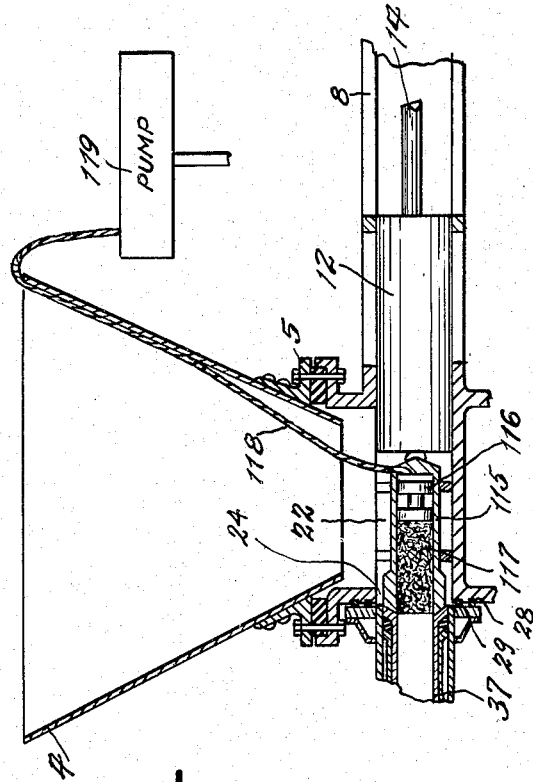
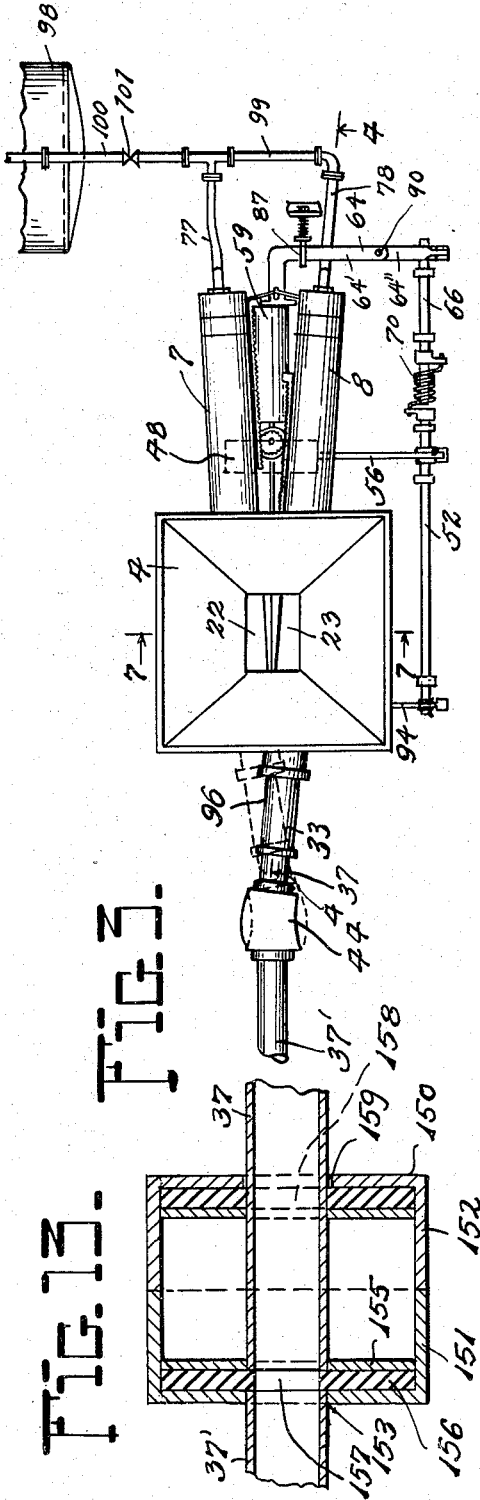

FIG. 10.

INVENTOR

EDWARD S. KARSTENS.

BY

Robert Robb

ATTORNEYS

Nov. 17, 1936.

E. S. KARSTENS

2,061,425

CONCRETE PUMPING MACHINE

Filed Aug. 21, 1934

6 Sheets-Sheet 4

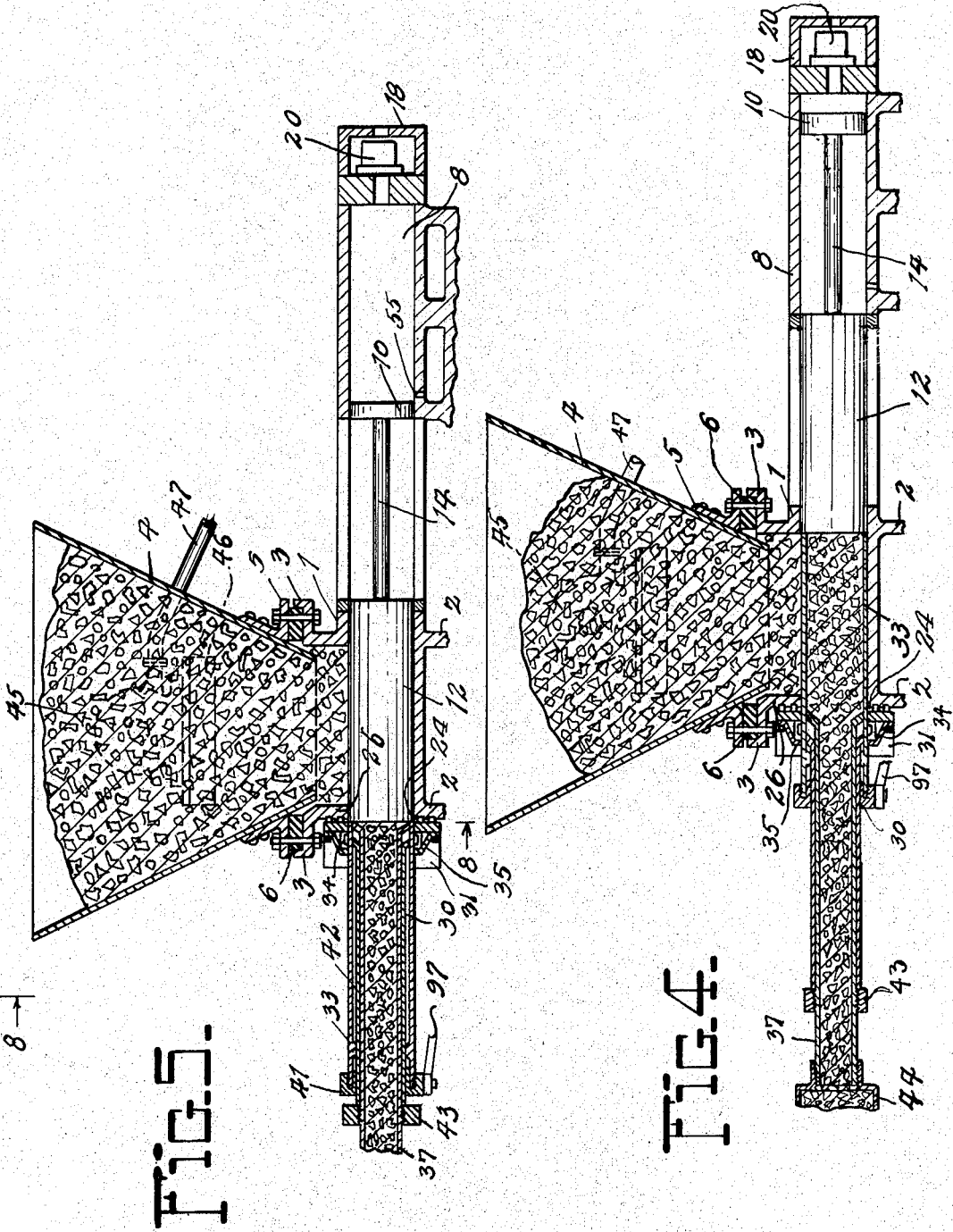

INVENTOR

EDWARD S. KARSTENS.

BY

Robert Cobb

ATTORNEYS

Nov. 17, 1936.

E. S. KARSTENS

2,061,425

CONCRETE PUMPING MACHINE

Filed Aug. 21, 1934

6 Sheets-Sheet 5

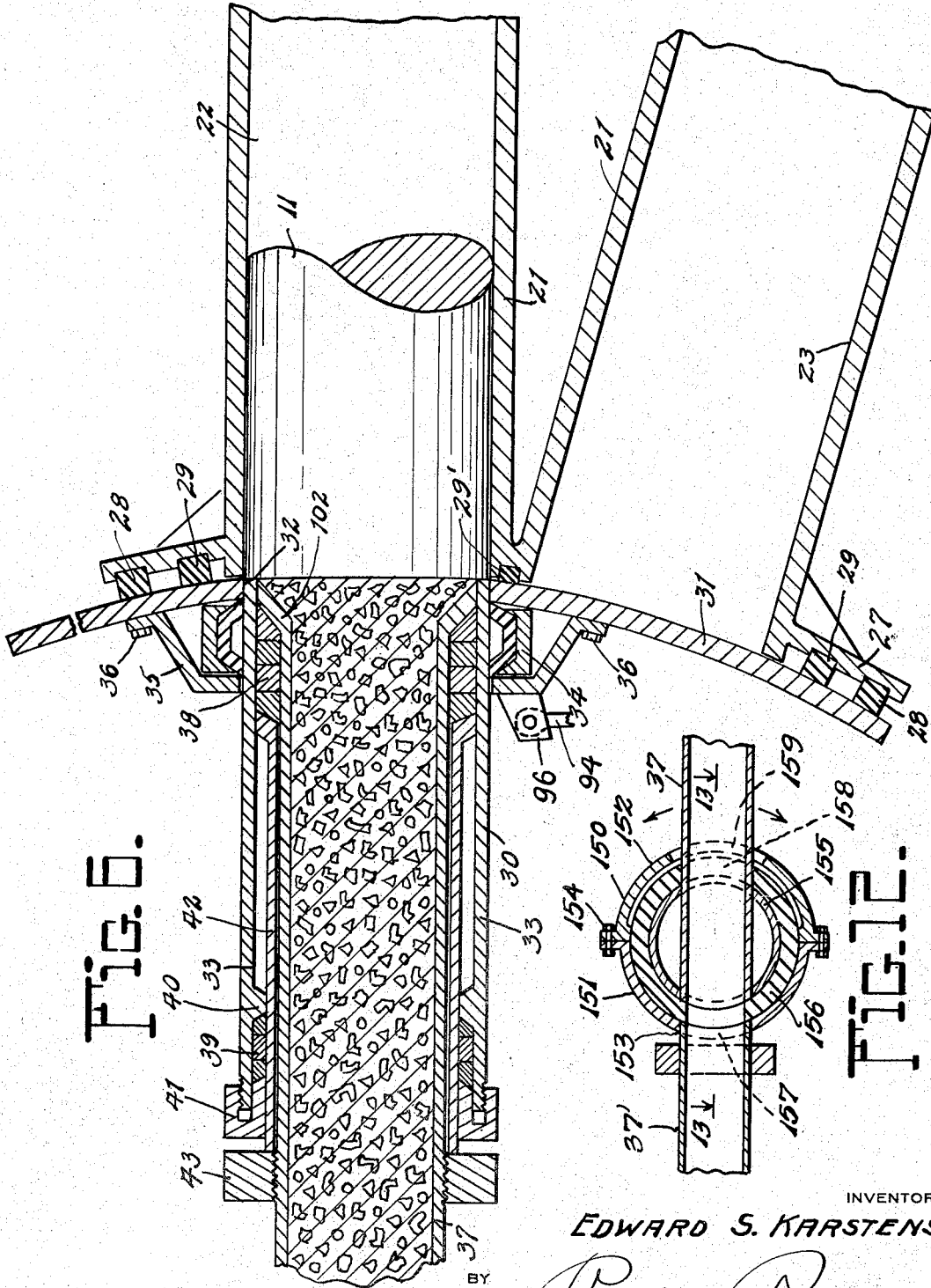

FIG. 6.

FIG. 12.

INVENTOR
EDWARD S. KARSTENS.

Robert Robb

ATTORNEYS

Nov. 17, 1936.

E. S. KARSTENS
CONCRETE PUMPING MACHINE

2,061,425

Filed Aug. 21, 1934

6 Sheets-Sheet 6

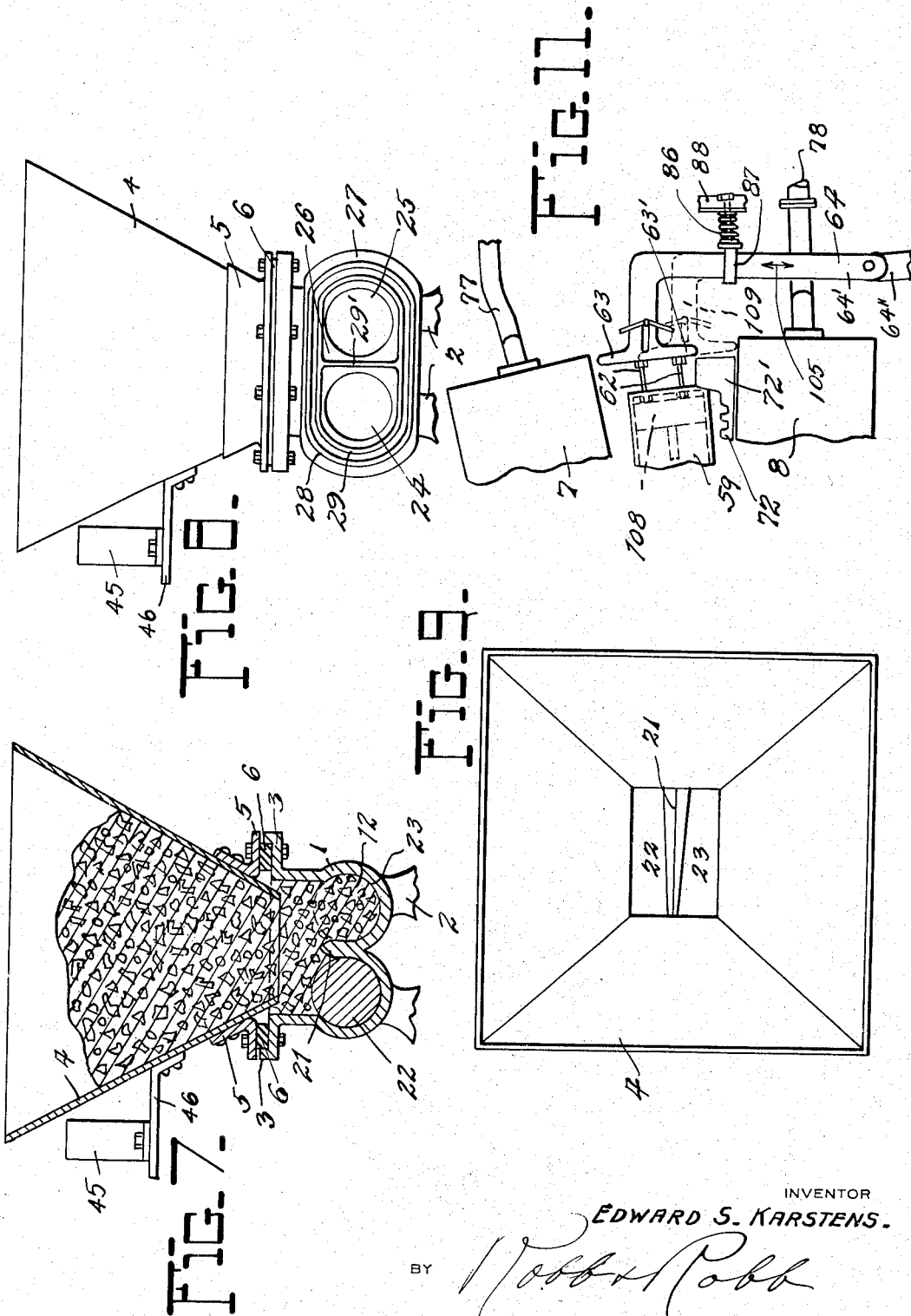

INVENTOR
EDWARD S. KARSTENS.

BY *Wobbe & Robb*

ATTORNEYS

UNITED STATES PATENT OFFICE

2,061,425

CONCRETE PUMPING MACHINE

Edward Siegfred Karstens, Davenport, Iowa, assignor of one-fourth to Koehring Company, Milwaukee, Wis., a corporation

Application August 21, 1934, Serial No. 740,829

18 Claims. (Cl. 103—227)

The object of the present invention has been to devise an improved pump and pumping system designed especially for the purpose of conveying and distributing plastic concrete to the site at which it is to be used. Systems of the type of the invention ordinarily involve the employment of some kind of pumping unit from which leads off a main conveyor pipe or conduit with which may be connected branch pipes or conduits going to different places in order to obtain the effective distribution of the concrete to different points of use thereof.

Pumping machines and systems of the class referred to present difficulties in obtaining efficient operation having to do primarily with the wear and tear on the pumping unit incident to the application of the pressure means for forcing the plastic concrete through the conveying and distributing conduits. Other problems are involved in reference to leakage of pressure in the conveyor lines.

An especial object therefore of the present improvements has been to design a peculiar type of pumping machine whereby a substantially continuous flow of the material being pumped may be secured and whereby the pressure means employed may act with high efficiency upon the plastic concrete in forcing the same through the conveyor or distributing lines or conduits. With the end just mentioned in view, the pumping machine employed in this invention comprises a supply hopper from which is fed in a gravitating manner to a plurality of ejector compartments of an ejector chamber, the mixed concrete.

Associated with the ejector compartments of said chamber I provide a special type of cut-off or separating device in the form of a valve which is adapted to selectively enter one or the other of the ejector compartments after the same is supplied with concrete from the hopper, and by so doing separates or cuts off a predetermined quantity of concrete in the particular ejector compartment from the bulk of the concrete materials of the hopper. Thereupon mechanism provided by me, including ejectors which work in the ejector compartments, cooperates with the said cut-off device or valve to move the same out of its particular selected compartment, and at the same time forces the concrete under pressure into the conveyor conduit provided therefor. The conveyor conduit has a flexible section which carries the cut-off device or valve and instrumentalities are employed whereby said flexible section and the cut-off valve as a selector unit are capable of being shifted so that the cut-off valve will coast

selectively and successively with the ejector compartments of the ejector chamber.

In addition to the foregoing features which are believed to embody a new principle of action of pumping machinery of the type of the invention, there are provided subsidiary features of improvement including vibrating or agitating means for the concrete in the hopper that supplies the compartments of the ejector chamber. Also I utilize special novel control mechanism for causing operation in timed relation of the selector unit including its cut-off valve to shift the same in reference to the ejector compartments and proper actions of the expelling devices for the ejector compartments which comprise plungers that work in conjunction with the cut-off valve that operates in the ejector compartments in its successive actions.

In the operation of my machine the instrumentalities employed act somewhat as a double acting pump in that the power strokes of two successive operating ejectors are directed against a single selector and cut-off unit while the return stroke of the ejector members is not availed of for the performance of working operations. I therefore obtain a continuous action of the pressure forces of my machine in relation to the plastic concrete, affording a very high degree of efficiency for a mechanism of this type.

Referring to the drawings—

Figure 1 illustrates a diagrammatic view of my concrete pumping machine illustrating the various instrumentalities which control the operation of the same.

Figure 2 is a view partially in section and partially in elevation disclosing the arrangement shown in Figure 1 in a more detailed manner.

Figure 3 is a top view of a concrete pumping machine as shown in Figures 1 and 2, and also disclosing additional parts.

Figure 4 is a vertical sectional view taken on line 4—4 of Figure 3, certain parts being omitted.

Figure 5 is a view similar to Figure 4 but illustrating the ejector and selector or cut-off valve in another position.

Figure 6 is a horizontal sectional view of the selector unit and ejector compartments, certain parts being broken away.

Figure 7 is a vertical sectional view taken on line 7—7 of Figure 3, illustrating more clearly the ejector chamber.

Figure 8 is an elevational view of the hopper and ejector chamber, looking in the direction of the arrows 8—8 in Figure 5.

Figure 9 is a top view of the hopper and dis-

closes more clearly the location of the partition within the ejector chamber.

Figure 10 is a vertical sectional view similar to Figure 4 and illustrates additional apparatus 5 which may be used for cleaning of the feed section of the conveyor pipe or distributing conduit.

Figure 11 is a fragmentary view of the trip end valve control mechanism.

Figure 12 is a horizontal sectional view of a 10 modified flexible joint.

Figure 13 illustrates a vertical sectional view taken on lines 13—13 of Figure 12.

Referring now to Figures 1 to 5 of the drawings, 1 illustrates the ejector chamber which is provided with a base or supporting structure 2 and a flange portion 3. Upon the flange 3 of the ejector chamber is mounted a hopper 4 provided with an attachment flange 5. Interposed between the flange 3 of the ejector chamber 1 and the flange 5 of the hopper is a resilient member 6 for the purpose of preventing transmission of vibrations from the hopper to the ejector chamber, for reasons as will be mentioned later on. Mounted on the ejector housing 1 are ejector cylinders 7 25 and 8. These cylinders are connected to the ejector chamber by means of flanges or the like, not shown, or they may be integral with said ejector chamber, as will be clearly seen from Figures 4 and 5. Within the ejector cylinders 7 and 8 are mounted ejector pistons 9 and 10 connected to ejectors 11 and 12 by means of piston rods 13 and 14. The ejector cylinder portions 15 and 16 adjacent the ejector chamber 1 are of a construction similar to the crosshead guide member of a steam engine, while the portions 7' and 8' of the ejector cylinders form the cylinders proper. The ends of the ejector cylinders 7 and 8 are provided with valve compartments 17 and 18 in which 40 of the ejector pistons 9 and 10, are mounted. The structure of the valve compartment and valves and the operation of the latter will be referred to later on more specifically.

The ejector chamber, as will be seen from Figure 7, forms a continuation of the piston guides 45 15 and 16 and is of such a configuration as to provide a guide for the ejectors 11 and 12. The ejector cylinders are in angular relationship with respect to each other, as will be clearly seen from 50 Figures 2 and 3. The opposing wall portions of the cylinders 7 and 8 form within the ejector chamber an integral partition wall 21, see Figure 7, so as to divide the ejector chamber into the ejector compartments 22 and 23, and within 55 which the ejectors 11 and 12 slide during performance of their working operations.

The ejector chamber is provided with two circular openings 24 and 25 which are in proper alignment with the ejector compartments 22 and 60 23. These openings are within the wall portion 26 of the ejector chamber as will be seen from Figures 4 and 8. The wall portion 26 of the ejector chamber is also provided with a flange 27 which is of an oval configuration and forms an 65 integral part of the portion 26. This flange 27 is provided with packing rings 28 and 29.

Mounted adjacent the wall portion 26 of the ejector chamber 1 is a selector unit 30 which 70 comprises a concavo-convex closure member 31 which is arranged to properly engage in fluid-tight relation with packings 28 and 29 of flange 27 of the ejector chamber 1. The flange 27 is of a configuration similar to the closure member 31 so that in all positions which the closure member 75 31 may assume with respect to the flange 27, prop-

er contact between the packings 28, 29 and the closure member 31 will be maintained.

The packing member 29 is also provided with a center portion 29' as clearly shown in Figures 6 and 8 to establish a fluid-tight connection between the closure member 31 and said packing, 5 and between the ejector compartments 22 and 23 and openings 24 and 25 in front of the wall portion 26. Packing portion 29' is not absolutely necessary and may be omitted. 10

The closure member 31 is provided with an opening 32 which receives the selector or cut-off valve 33. The selector and cut-off valve 33 is held in proper position with respect to the closure member 31 by means of packings 34 and the retaining member 35 secured to the closure member 31 by means of screws 36. A distributing conduit or conveyor pipe 37 is arranged within the selector or cut-off valve 33, and packings 38 and 39 are provided to maintain a fluid-tight seal between the selector or cut-off valve 33 and the feed section of the distributing conduit or conveyor pipe 37. Packing 39 is properly held in place between an annular shoulder 40 of the selector 33 and retaining member 41. In a like 25 manner packing 38 is maintained in proper compressed position by means of a sleeve 42 and retaining member 43. The retaining member 41 is secured to the selector 33 in a manner obvious from Figure 6; and the retaining member 43 is 30 secured to the feed section of the distributing conduit in a like obvious manner. The packings 38 and 39 may be compressed by tightening the retaining members 41 or 43 to properly maintain their sealing functions. 35

From Figure 6 it will be noted that the selector or cut-off valve is arranged in such a manner that it may slide in a longitudinal direction with respect to the feed section 37 of the distributing conduit and ejector compartments 22 and 23. 40 The feed section 37 of the distributing conduit is not movable in a longitudinal direction with respect to the ejector compartments 23 and 22, but may move transversely with respect to the same if the selector 33 is out of contact with the ejector 45 compartments 22 and 23.

The transverse movement of the entire selector unit 30 which has just been mentioned is accomplished by controlling instrumentalities which will be later described. The purpose of the transverse movement of the ejector unit is to bring 50 the feed section and the selector into alignment with either the ejector compartment 22 or the ejector compartment 23. To permit this transverse movement of the selector unit 30 it is necessary to provide the distributing conduit or conveyor pipe 37 and 37' with a flexible joint 44 as clearly shown in Figure 3. The selector or cut-off valve may slide into either the ejector compartment 22 or the ejector compartment 23, 60 depending upon which of said compartments said selector is in alignment with. This movement of the selector or cut-off valve is caused by instrumentalities and control mechanism which will be mentioned while the description proceeds. 65

The distributing conduit or conveyor pipe 37 and 37' may be of any length and elevation which is practically admissible for concrete pumping machines of this character. If the concrete is 70 to be pumped to elevations which are higher than the location of the machine, a control valve should be arranged within the conduit 37 so as to prevent the back-flow of the concrete mixture from the distributing conduit 37 into the ejector 75

compartments 22 and 23. Such control valve construction has not been disclosed in this application, but any commercial valve structure which would be adaptable for such purpose may be used.

A vibrator 45 may be mounted on one of the side walls of the hopper 4 in any convenient manner, as for instance by use of a bracket 46, to impart vibration to the hopper for accomplishing the proper discharge of mixed aggregates from the hopper into the ejector chamber and to eliminate the sticking of aggregates to the side wall of the hopper 4.

The vibrator 45 may be a small steam turbine the shaft of which is arranged slightly off center so that upon rotation of the moving turbine parts vibrations are imparted to the hopper structure to perform the functions set forth above. The steam turbine 45 may be connected

to a source of power by means of the conduit 47. Referring now more specifically to Figures 1, 2, and 3, it will be noted that a cylinder 48 is mounted beneath the cylinders 7 and 8. Arranged within this cylinder is a selector control piston 49 which is connected by means of a piston rod 50 to a crank arm 51 which is mounted on a control shaft 52 in fixed relation. The ejector cylinder 7' is connected with an opening 53 from which a conduit 54 leads into the selector control cylinder 48. In a like manner the ejector cylinder 8' is provided with an opening 55 from which the conduit 56 leads into the selector control cylinder 48. Both conduits 54 and 56 enter into cylinder 48 at the opposite ends thereof, as will be clearly seen from Figure 1. The wall of the selector control cylinder 48 is also provided with an opening 57 at its center, and a conduit or pipe 58 connects the selector control cylinder 48 with the retractor control cylinder 59. Within the retractor control cylinder is arranged a retractor control piston 60 to which a piston rod or retractor member 61 is secured. The end wall of the retractor control cylinder opposite the conduit 58 is provided with pusher members 62 which extend through the said end wall and are movably arranged to engage arms 63 and 63' of a trip and valve control device 64. Said valve control device is pivotally mounted to a crank 65 attached to a shaft 66 in fixed relation. The control shaft 52 and the shaft 66 are also provided with crank arms 67 and 68 which are keyed to the respective shafts just mentioned. Interposed between the crank arms 67 and 68 is a helical spring 69 which is attached to cranks 67 and 68 in a manner as will be obvious from Figure 2. The parts 67, 68, and 69 constitute a power storing device for delayed movement control. This power storing device is generally indicated by the numeral 70 and will be referred to later on when the control operations of the various control instrumentalities are described.

The ejectors 11 and 12 are connected to control racks 71 and 72 by means of bolts 73 and 74. The control racks 71 and 72 are adjacent the walls of cylinders 7 and 8 and are movable with respect thereto. Interposed between the control racks 71 and 72 is a gear 75. The teeth of the gear 75 are in engagement with the teeth of the racks 72 and 71, as clearly illustrated in Figure 2. The shaft 76 on which the gear 75 is mounted is supported by the frame structure of the machine in any convenient manner (not shown).

Referring now more specifically to the valve compartments 17 and 18, it will be noted that

the same are provided with inlet conduits 77 and 78 and outlet or exhaust passages 79 and 80. Passages 81 and 82 establish a connection between the valve compartments 17 and 18 and the cylinders 7' and 8'. The slide valves 19 and 20 are adapted to control the connection between the cylinders 7' and 8' and the valve compartments 17 and 18 or exhaust passages 79 and 80. In other words, valves 19 and 20 operate in the same manner as the valves of a steam engine and a further description is therefore not deemed necessary. The valves 19 and 20 are connected with the trip and valve control device by means of valve rods 83 and 84. The trip and valve control device 64 is provided with a slot 85 in which the ends of the valve rods 83 and 84 are slidably mounted so that upon motion of the trip and valve control device in a direction as indicated by the arrow 200 in Figure 2, the position of the valve rods 83 and 84 will not be varied. This slidable connection between the valve rods and the trip and control device is necessary to prevent the bending of said rods during operation of the trip and valve control device.

The control racks 71 and 72 are provided with abutment portions 71' and 72' which are adapted to cooperate with arms 63 and 63' to control the operation of the trip and valve control mechanism as will be described later on.

The trip and valve control device is held in its normal position as shown in Figure 2 by means of a coil spring 86 interposed between an attachment member 87 on the trip and valve control device and frame of the machine, a portion of which is shown in Figure 2 and indicated by the reference numeral 88. The trip and valve control device may slide within the attachment member 87 in a direction as indicated by the arrow 105 in Figure 11. To permit free movement of the trip and valve control device, the same is composed of portions 64' and 64'' which portions are pivotally interconnected as shown at 90.

Bearings 91 and 92 are provided to support the control shaft 52 and shaft 66. Attached to one end of the control shaft 52 is a crank arm 93 to which a selector control rod 94 is pivotally secured at 95. The other end of the selector control rod 94 is attached to the retaining member 35 of the cut-off valve 33 by means of an attachment member 96 integral with said retaining member.

The retractor member 61 which is secured to the retractor control piston 60 is connected by means of a retractor rod 97 to the retaining member 41 previously referred to. Inlet conduits 77 and 78 are connected to a steam boiler 98 by means of conduits 99 and 100. A valve 101 is provided to control the flow of energy from the steam boiler 98 as will be seen from Figures 2 and 3.

The feed section 37 of the distributing conduit or conveyor pipe is provided with a scraper portion 102 as clearly seen from Figure 6, and its function will more fully appear hereinafter.

Operation of concrete pumping machine

Referring now to Figures 1 and 2 and assuming that the control mechanism of the pumping machine is in the position indicated in these figures, it will be noted that steam enters from the boiler 98, over conduits 100 and 77, into the valve compartment 17, through passage 81, into cylinder 7'. The piston 9 has just completed its power stroke and the steam may travel now

through opening 53, conduit 54, into cylinder 48, and the selector control piston 49 will move in a direction indicated by the arrow 103 in Figure 1, thereby imparting rotation by means of piston rod 50 and crank 51 to control shaft 52. Rotation of control shaft 52 and crank 93 exerts a pull on the selector control rod 94 which will move in the direction of arrow 104 and thereby shift the selector unit 30 from its position as shown in Figure 6 to the position as illustrated in Figure 3, thereby moving the said selector unit 30 into proper alignment with the ejector compartment 23.

The trip and valve control device 64 is at this time in a position as shown in Figures 1 and 2 and the arm 63' of the valve control device contacts with the abutment 72' of control rack 72 and a movement of the trip and valve control device in the direction of arrow 105, see Figure 2, is thereby prevented. The rotation of control shaft 52 will therefore wind up spring 69 of the power storing device for delayed movement control, and spring 69 will be then held under tension in view of the fact that shaft 66 cannot rotate as long as arm 63' contacts with abutment 72'. The selector control piston 49 has now reached its dotted line position as shown at 106 in Figure 1. The steam entering the cylinder 48 passes through the opening 57, conduit 58, into the retractor cylinder 59, and retractor control piston 60 will move in a direction indicated by arrow 107 in Figure 1. The retractor control piston 60 will now reach its dotted line position as indicated in Figure 11 at 108 and thereby force the pusher members 62 outwardly against the arms 63 and 63' of the trip and valve control device 64. The trip and valve control device 64 will now assume its full line position of Figure 11. The arm 63' will be moved out of contact with the abutment member 72' and the power controlling device 70, the spring of which has been held under tension as previously described, now comes into function and moves the power trip and valve control device 64 to a position as shown in dotted lines at 109 in Figure 11. The power stroke of the retractor control piston causes a corresponding movement of the retractor 61, retractor rod 97, and the selector and cut-off valve 33. As above mentioned, the selector and cut-off valve 33 is now in alignment with the ejector compartment 23, and under the influence of the power stroke of the retractor control piston the selector and cut-off valve now enters the ejector compartment 23 which is filled with concrete, as will be seen from Figure 7, and the valve now separates a certain quantity of aggregates within the ejector chamber from the remaining mass of concrete within the latter and confines the same within its tubular space. This movement of the selector or cut-off valve into compartment 23 continues until the selector 33 abuts against ejector 12. The selector member 33 will now be in a position as shown in Figure 4, and, as already mentioned, the space confined by said cut-off valve 33 is now entirely filled with concrete. The movement of the trip and valve control device above referred to will cause a corresponding movement of the valves 19 and 20 which are connected by means of rods 83 and 84 to said trip and valve control device 64. Valves 19 and 20 will therefore now assume the positions indicated in dotted lines in Figure 1. Passage of steam to cylinder 7' is now cut off and cylinder 7', is connected with the exhaust 79.

Steam now enters from the valve compartment

18 through passage 82 into cylinder 8', and the ejector piston 10 will perform its power stroke in a direction as indicated by arrow 110. The ejector 12 which was at the beginning of the power stroke of ejector piston 10 in the position as shown in full lines in Figure 4, moves upon the power stroke of ejector piston 10 into the ejector compartment 23 and forces the selector or cut-off valve over the feed section of the distributing or conveyor pipe 37 until the end of the ejector 12 abuts against the scraper portion 102 of said feed section. The concrete which had been confined and separated within the selector and cut-off valve is thereby forced into the feed section 37 of the distributing conduit. The scraper portion 102 which is in close contact with the inner wall of the selector or cut-off valve cleans the inner surface thereof so that no concrete aggregates will be forced into the packing 38.

The retractor control piston 60 has now returned to its full line position in Figure 1, and such return movement of said piston has been caused by the movement of the selector and cut-off valve just described in view of the fact that these two elements are coupled together by means of members 61 and 97.

The ejector piston 10 and ejector 12 have now reached the end of their power stroke and are in the position shown in Figure 5. The steam in the cylinder 8' travels now through opening 55 of cylinder piston 8', over conduit 56, into piston 48, and moves the selector control piston 49 from its dotted line position as shown at 106 in Figure 1 to its full line position of said figure. Previously to such motion of piston 49, rack 72 has been moved in the direction of the arrow 201 indicated in Figure 2. In view of the fact that this rack 72 is connected to the ejector 12, it is therefore bound to move in unison with the same. Movement of rack 72 in the direction just mentioned causes rotation of the gear 75, thereby returning ejector 11 in the direction of arrow 111, as illustrated in Figure 2, until the ejector 11 and ejector piston 9 reach their original position, the ejector piston 9 now being adjacent to the inlet passage 81. The rack 71 has been moved in unison with ejector 11 and ejector piston 9 and is now in a position so that the abutment portion 71' is opposite arm 63 of the trip and valve control device 64. As previously mentioned, the selector control piston 49 has reached its full line position as shown in Figure 1, thereby turning control shaft 52, to which said piston is connected by means of piston rod 50, in a direction opposite to that previously described before the power stroke of ejector piston 10. The spring 69 is tensioned and the arm 63 now abuts against the abutment portion 71' of the control rack 71. At the same time rotation of shaft 52 causes the return of the selector unit from the position shown in Figure 3 to the full line position as shown in Figure 6, so that the selector and cut-off valve is now in alignment with the ejector compartment 22.

Steam now enters through opening 57, conduit 58, into the retractor cylinder, and forces the retractor piston again in the direction indicated by the arrow 107 in Figure 1, thereby pushing the selector and cut-off valve into the ejector compartment 22, and the selector will separate and confine within its limits another quantity of concrete mixture in the same manner as previously described with reference to ejector com-

partment 23. The retractor control piston now reaches the end of its power stroke and abuts against pusher members 62 which are forced against arms 63 and 63', causing motion of the trip and valve control device 64 in the direction as indicated by arrow 112 in Figure 1, until the arm 63 slides off the abutment member 71', at which moment the power storing device comes into function, moving the trip and control device in the direction of arrow 113 as clearly seen in Figure 1. This causes a return of the valves 19 and 20 from their dotted line to their full line position in Figure 1. The cylinder 8' is now connected with the exhaust 80 and steam now enters through passage 81 into cylinder 7', forcing the ejector piston 9 and ejector 11 in the direction of arrow 114, as illustrated in Figure 1, thereby causing discharge of the concrete aggregates within the cylinder or cut-off valve 33 into the feed section 37 of the distributing conduit or conveyor pipe in the manner previously described. The retractor piston 60 is returned to its full line position of Figure 1, and as soon as the ejector piston 9 reaches the end of its power stroke, steam will pass from cylinder 7', through opening 53, conduit 54, into selector control cylinder 48, and the entire cycle of the machine as described above repeats.

It will be noted from the foregoing that the return stroke of the ejectors 11 and 12 is not availed of for performing the working operation and the vacuum created upon the return stroke of said ejectors within their respective compartments, which are now closed against the atmosphere by the closure member 31, will be of no consequence in view of the fact that the packings 28, 29 and 29' are not in sufficient sealing contact with the closure member 31 to prevent the entrance of air in the respective ejector compartment to destroy such vacuum. If, however, an absolute seal between the packings 28, 29 and 29' and the closure member 31 is desired, the ejectors 11 and 12 may in such case be provided with valves which will open upon the return stroke of the ejectors 11 and 12 under the influence of the vacuum created in the ejector compartments to immediately destroy the vacuum therein. Such valve arrangement or bleeding of the packings 28, 29 and 29' is hardly believed necessary because upon the return stroke of each ejector 11 or 12 the aggregates contained in the hopper 4 and ejector chamber will flow into the space of the ejector compartments 22 and 23 which is made free upon the return of the ejectors.

From the foregoing it will be seen that predetermined quantities of the concrete which are separated from the concrete mixture in the ejector chamber and hopper will be forced successively into the distributing conduit 37, and the aggregates may in this way be distributed through the distributing conduit 37 to any desired location which may be of a higher or lower elevation with respect to the concrete pumping machine. If the concrete is to be distributed to a higher elevation, a control valve has to be arranged within the distributing conduit 37 at some convenient place, as already described.

Figure 10, which shows a longitudinal cross sectional view through the hopper, ejector chamber, and a portion of the feed section of the distributing conduit 37, illustrates also some additional apparatus which may be used for cleaning the feed section of the distributing conduit. To

clean the apparatus heretofore described an auxiliary cylinder 115, which comprises a go-devil or chaser member 116, is inserted through the hopper into the ejector chamber and one of the ejectors 11 or 12 is forced against the end of the auxiliary cylinder 115 by proper manipulation of the control valve 101 so that the auxiliary cylinder will be held in proper alignment with the feed section of the distributing conduit 37. The space of the auxiliary cylinder in front of the go-devil or piston member 116 is filled with excelsior (as indicated at 117). A flexible conduit is attached to the auxiliary cylinder as clearly shown at 118, and pressure may be supplied from a pump 119 driven in any convenient manner into cylinder 115 so that the piston member 116 and the excelsior 117 will be forced into and through the feed section of the distributing pipe 37. The distributing pipe 37 is thereby cleaned from all the aggregates which might adhere to its walls, and upon completion of this cleaning operation the auxiliary cylinder may be removed.

The vibrator 46 which is mounted on the hopper 4 functions as an agitating means to ensure the entry of the concrete aggregates into the ejector chamber.

In Figures 12 and 13 there is shown a modified form of flexible joint which may be used to great advantage.

As will be seen from Figure 12, the flexible joint 150 comprises a cylindrical housing having the portions 151 and 152. The housing portion 151 is welded to conduit 37' at 153 while the housing portion 152 is secured to housing portion 151 by means of bolts 154. The conduit 37 is provided with a cylindrical member 155 which is welded thereto. Interposed between housing 150 and the cylindrical member 155 is a cylindrical packing of resilient material as indicated at 156 having passages 157 and 158. The housing portion 152 is also provided with an opening 159 permitting free movement of conduit 37. This disalignment between conduit 37 and 37' upon displacement of conduit 37 during the operation of the machine is negligible and will not exceed ten degrees.

Having thus described my invention, what I claim as new and desire to secure by Letters Patent of the United States, is—

1. A concrete pumping machine of the character described, comprising, in combination, an ejector chamber adapted to contain concrete aggregates, a distributing conduit associated with the ejector chamber and in fixed relation with respect thereto, an open-ended cut-off valve movably mounted relative to the distributing conduit, mechanical instrumentalities for positively moving said cut-off valve into the ejector chamber for receiving through the open end of the cut-off valve and separating and confining a predetermined quantity of concrete aggregates within the cut-off valve, and ejector means for actuating the cut-off valve and forcing said predetermined quantity of concrete aggregates from the ejector compartment into the distributing conduit.

2. A concrete pumping machine of the character described, comprising, in combination, an ejector chamber adapted to contain concrete aggregates, a distributing conduit associated with the ejector chamber and in fixed relation with respect thereto, an open-ended cut-off valve movably mounted relative to the distributing conduit, mechanical instrumentalities for positively moving said cut-off valve into the ejector chamber

- for receiving through the open end of the cut-off valve and separating and confining a predetermined quantity of concrete aggregates within the cut-off valve, ejector means for actuating the cut-off valve and forcing said predetermined quantity of concrete aggregates from the ejector compartment into the distributing conduit, and common actuating devices for actuating the said cut-off valve and ejector means.
3. A concrete distributing apparatus, comprising, in combination, an ejector chamber adapted to contain mixed concrete or the like, a distributing conduit adjacent the ejector chamber, an open-ended tubular cut-off valve surrounding the distributing conduit and movable with respect thereto, retractor instrumentalities for moving the cut-off valve endwise into the ejector chamber to thereby charge said cut-off valve through one of its open ends with a predetermined quantity of mixed concrete, pressure means for expelling said predetermined quantity from the ejector chamber and cut-off valve, and instrumentalities for actuating the pressure means and cut-off valve.
4. A concrete distributing apparatus of the character described, comprising, in combination, an ejector chamber comprising a plurality of ejector compartments, a hopper mounted upon said ejector chamber, a plurality of ejectors for cooperation with the ejector compartments, a source of power for operating the ejectors, a cut-off valve transversely movable with respect to the ejector compartments for selective cooperation therewith, and longitudinally movable respecting the selected compartment, instrumentalities for controlling the movement of the cut-off valve, and timing mechanism connecting the instrumentalities for controlling the cut-off valve and said source of power for inter-relating the operation of said instrumentalities with the source of power.
5. A concrete distributing apparatus of the character described, comprising, in combination, an ejector chamber comprising a plurality of ejector compartments, a hopper mounted upon said ejector chamber, a resilient member between the hopper and ejector chamber, a vibrator mounted upon said hopper, a plurality of ejectors for cooperation with the ejector compartments, a source of power for operating the ejectors, a cut-off valve transversely movable with respect to the ejector compartments for selective cooperation therewith, and longitudinally movable respecting the selected compartment, instrumentalities for controlling the movement of the cut-off valve, and timing mechanism connecting the instrumentalities for controlling the cut-off valve and said source of power for inter-relating the operation of said instrumentalities with the source of power.
6. A concrete pumping machine of the character described, comprising, in combination, an ejector chamber comprising compartments adapted to contain concrete aggregates or the like, a selector unit adjacent to said ejector chamber and comprising a distributing conduit and a cut-off valve selectively movable with respect to said ejector chamber compartments, the cut-off valve being adapted to separate a predetermined quantity of concrete aggregates from the bulk of concrete aggregates within the ejector chamber, ejector means operatively associated with the ejector chamber for expelling the predetermined quantity of concrete aggregates from the cut-off valve and into the distributing conduit, a control shaft, a selector mechanism connected to said control shaft, means interconnecting the control shaft and cut-off valve for moving the latter selectively with respect to the ejector chamber compartments, retractor means connected to the cut-off valve for moving the cut-off valve into the selected ejector compartment, control racks connected to the ejector means and movable therewith, a valve mechanism cooperating with the retractor means and control racks, a second shaft operatively interconnected with the valve mechanism, a power storing device between the first mentioned shaft and said second shaft, a common source of power for the ejector means, selector mechanism and retractor means, power control valves and instrumentalities interconnecting the latter with the valve mechanism for controlling the ejector means, selector mechanism and retractor means in timed relation incident to tripping of the valve control device, and conduit means for connecting the ejector means, selector mechanism and retractor means to the common source of power.
7. In a concrete pumping machine, in combination, a supply hopper for concrete aggregates or the like, an ejector chamber associated with the said hopper to which chamber the aggregates may gravitate from the hopper, agitating means for the aggregates in the hopper to ensure the entry of said aggregates into the ejector chamber, an open-ended cut-off valve defining a hollow aggregate receiving compartment within the same, means for moving the cut-off valve into the ejector chamber to separate a predetermined quantity of the aggregates in said chamber from the bulk of the aggregates in the hopper supplying said chamber, and ejector mechanism cooperating with the cut-off valve for ejecting the separated portion of the aggregates handled by the cut-off valve, said ejector mechanism including a plunger movable into and out of the ejector chamber and relatively to said cut-off valve, said plunger being axially aligned with the cut-off valve, and, when moved into the ejector chamber, being adapted to abut against the open end of said cut-off valve so as to close said end and transmit its motion to the cut-off valve.
8. In a concrete pumping machine, in combination, a supply hopper, an ejector chamber associated therewith to receive predetermined quantities of material from the hopper, said chamber comprising a plurality of ejector compartments, a selector unit comprising a hollow cut-off valve selectively movable to cooperate with a selected one of the ejector compartments to separate a predetermined quantity of material fed therinto from the supply of material in the hopper and confine the same within the cut-off valve, and means for ejecting the material so separated by the cut-off valve when cooperating with a selected one of the ejector compartments.
9. In a concrete pumping machine, in combination, a supply hopper, an ejector chamber associated therewith to receive predetermined quantities of material from the hopper, said chamber comprising a plurality of ejector compartments, a selector unit comprising a cut-off valve selectively movable to cooperate with a selected one of the ejector compartments to separate a predetermined quantity of material fed therinto from the supply of material in the hopper, and means for ejecting the material so separated by the cut-off valve when cooperating with a selected one of the ejector compartments, said ejecting means including a plurality of ejectors, one for each ejector compartment, each of said

ejectors being adapted to coact with the cut-off valve for ejecting the material separated by said valve in its ejector compartment.

10. In a concrete pumping machine, in combination, a supply hopper, an ejector chamber associated therewith to receive predetermined quantities of material from the hopper, said chamber comprising a plurality of ejector compartments, a selector unit comprising a cut-off valve selectively movable to align with a selected one of the ejector compartments and adapted to move into said compartments to separate a predetermined quantity of material fed thereto from the supply of material in the hopper, means for ejecting the material so separated by the cut-off valve when cooperating with a selected one of the ejector compartments, and actuating means for the cut-off valve for selectively shifting the same into alignment with each ejector compartment, and with means for causing movement of the cut-off valve into such ejector compartment with which it may be aligned.

11. In a concrete pumping machine, in combination, a supply hopper for aggregate materials or the like, an ejector chamber associated therewith to receive materials therefrom and comprising an ejector compartment, a distributing conduit, a cut-off valve movably mounted on the outside of the distributing conduit and shiftable therefrom into the ejector compartment, and ejector means associated with the cut-off valve to force material separated by the cut-off valve from the bulk of material from the hopper when said cut-off valve is moved into the ejector compartment for such purpose, whereby the material may be ejected from the ejector compartment into the distributing conduit.

12. In a concrete pumping machine, in combination, a supply hopper for aggregate materials or the like, an ejector chamber associated therewith and comprising a plurality of ejector compartments, a distributing conduit, a selector unit associated with said conduit and comprising a cut-off valve movable into positions in which it is adapted to enter either one of the ejector compartments, means for moving the cut-off valve into a selected ejector compartment to separate material therein from the bulk of material in the hopper ready for delivery to the distributing conduit, mechanism for positioning the selector unit in selective relation to either one of the ejector compartments, and ejectors cooperative with the ejector compartments to expel material therein as may be separated from the bulk of material in the hopper by the movement of the cut-off valve to said ejector compartment.

13. A concrete pumping machine, comprising, in combination, an ejector compartment adapted to contain concrete aggregates, and comprising a plurality of ejector chambers, a cut-off valve selectively movable with respect to the ejector compartments, valve controlled ejector mechanism cooperating with the cut-off valve and ejector compartments for expelling concrete aggregates from the ejector compartments, devices for moving the cut-off valve in alignment with the ejector compartments successively, instrumentalities for forcing the cut-off valve into the ejector compartments in a predetermined and successive manner, control valves for cooperation with the ejector mechanism,

a trip control mechanism connected to said valves and operatively associated with the said instrumentalities and cut-off valve moving devices, and a delayed movement power storing device for tripping the trip control mechanism to thereby control the cycles of operation of the ejector mechanism and cut-off valve.

14. A concrete pumping machine, comprising, in combination, an ejector compartment adapted to contain concrete aggregates and comprising a plurality of ejector chambers, a cut-off valve selectively movable with respect to the ejector compartments, valve controlled ejector mechanism cooperating with the cut-off valve and ejector compartments for expelling concrete aggregates from the ejector compartments, devices for moving the cut-off valve in alignment with the ejector compartments successively, instrumentalities for forcing the cut-off valve into the ejector compartments in a predetermined and successive manner, control valves for cooperation with the ejector mechanism, a trip control mechanism connected to said valves and operatively associated with the said instrumentalities and cut-off valve moving devices, a delayed movement power storing device for the trip control mechanism, and control racks comprising abutment portions adapted to engage the trip control mechanism for controlling the action of the latter relative to the position of the ejector mechanism.

15. A concrete pumping machine, comprising, in combination, an ejector compartment adapted to contain concrete aggregates and comprising a plurality of ejector chambers, a cut-off valve selectively movable with respect to the ejector compartments, valve controlled ejector mechanism cooperating with the cut-off valve and ejector compartments for expelling concrete aggregates from the ejector compartments, devices for moving the cut-off valve in alignment with the ejector compartments successively, instrumentalities for forcing the cut-off valve into the ejector compartments in a predetermined and successive manner, control valves for cooperation with the ejector mechanism, pusher members movably inter-connected with said instrumentalities, a trip control mechanism connected to said ejector mechanism valves and contacting with the pusher members and operatively associated with the said instrumentalities and cut-off valve moving devices, control racks comprising abutment portions adapted to engage the trip control mechanism, and a power storing device for tripping the trip control mechanism upon release from the abutment portions of the control racks to thereby control the cycles of operation of the ejector mechanism and cut-off valve.

16. A pumping machine of the character described, comprising, in combination, an ejector chamber including a plurality of ejector compartments, a distributing conduit communicating with said ejector chamber, a cut-off valve associated with the distributing conduit and movable with respect to the latter and the ejector chamber, means for positioning said cut-off valve for selectively establishing operative relation between said cut-off valve and said ejector compartments, means for retracting the cut-off valve within the selected compartment, a plurality of ejectors movable with respect to the ejector compartments, actuating means for said ejectors, control means for actuating the cut-off valve positioning means aforesaid in proper timed relation, a source of power for operating the ejector

actuating means, the cut-off valve positioning means and the cut-off valve retracting means, and control instrumentalities between the cut-off valve control means and said source of power for controlling the movement of the ejectors in timed relationship with respect to the operation of the cut-off valve.

17. A pumping machine of the character described, comprising, in combination, an ejector chamber including a plurality of ejector compartments, a distributing conduit communicating with said ejector chamber, a cut-off valve associated with the distributing conduit and movable with respect to the latter and the ejector chamber, selector mechanism for selectively positioning the cut-off valve in operative relation to said ejector compartments, means for retracting the cut-off valve into the selected compartment, a plurality of ejectors movable with respect to the ejector compartments, one for each compartment, operating means for said ejectors, including control means therefor, control mechanism cooperating with the retractor means and selector mechanism, and a source of power for the selector mechanism, the cut-off valve retracting means and the ejector operating means, said

source of power serving to move the cut-off valve in alignment with the ejector compartments in successive order, to move the cut-off valve into the ejector compartment with which it is in alignment and to cause ejection operation of the ejector opposite the cut-off valve in timed relationship with the latter.

18. A pumping machine of the class described, comprising, in combination, an ejector compartment adapted to receive concrete aggregates, said ejector compartment including a plurality of open ended ejector chambers, a distributing conduit communicating with said ejector compartment, a cut-off valve selectively cooperable with the ejector chambers, means for selectively aligning the cut-off valve with the open ends of the ejector chambers, means for retracting the cut-off valve into the selected ejector chamber, an ejector for each ejector chamber, means for reciprocating the ejectors, and means for controlling the operation of the cut-off valve aligning means, the cut-off valve retracting means and the ejector reciprocating means in timed relation whereby to eject concrete aggregates alternately from the ejector chambers into the distributing conduit.

EDWARD S. KARSTENS.